



DATA SHEET FOR FLP HAND LAMP

HAND LAMP IIA & IIB, IIC UP TO 20 WATT LED

TECHNICAL DATA:

PRODUCT	:	CAT. NO.- RVL/2C/181
ENCLOSURE	:	FLAME PROOF (Ex -d), Gas Group IIA , IIB , IIC As per IS/IEC 60079-1 : 2014
PROTECTION	:	WEATHER PROOF IP – 66 AS PER IS/IEC 60529:2001 (Reaffirmed 2014)
AREA & TEMP. CLASS	:	Ex db IIC T6 Gb (EX tb / tc IIIC T85 C Db/Dc (ZONE 1 & 2 & Zone 21 & 22)
CERTIFICATION	:	CIMFR, BIS, PESO
TEMPERATURE CLASS	:	T 6
MATERIAL	:	DIE CAST ALUMINIUM ALLOY
FINISH	:	EPOXY POWDER COATED SHADE AS PER IS : 5
EARTHING	:	1 No INTERNAL & 2 No's EXTERNAL
HARDWARE	:	STAINLESS STEEL
GASKET	:	'O' RING ENDLESS GASKET NEOPRENE / SILICON
NAME PLATE	:	SS NAME PLATE CUM WARNING PLATE
GLASS	:	HEAT RESISTANT CLEAR TYPE-A TOUGHENED GLASS (FLAT)
ENTRIES	:	2 Nos M20 / ½ " NPT / EQUIVALENT
VOLTAGE	:	140 V – 270 V (240 V AC)
POWER FACTOR	:	≥ 0.95
INPUT FREQUENCY	:	50 Hz.
EFFICACY	:	≥ 100 LUMEN PER WATT
COLOUR (CCT)	:	3000K / 5700K / 6500 K / OR AS SPECIFIED
CRI	:	≥ 80 RA
THD	:	≤ 10 % THD
SURFACE TEMP.	:	MAX . 70°
LED MAKE	:	CITIZEN / OSRAM / BRIDGELUX / EQUIVALENT
DRIVER MAKE	:	FULHAM / EQUIVALENT – BIS APPROVED

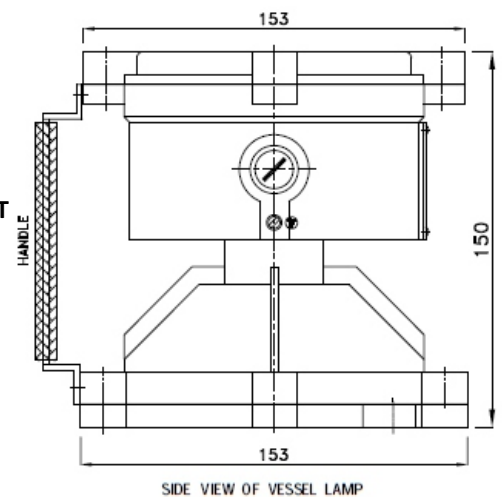

OPTIONS

SR.NO	PARTICULAR	OPTIONS
1.	MATERIAL OF CONSTRUCTION	STAINLESS STEEL
2.	VOLTAGE	220V DC / 110 V AC / 110 V DC / 24 V AC
3.	LED TYPE	COB / SMD
5.	GLAND & PLUG	BRASS / SS / ALUMINIUM
6.	COLOUR SHADE	631 , 632 , 355 , 7031 , 7032 etc.

SELECTION CHART

SR.NO	WATTAGE	PART NO
1	15	RVL/ 2C / 181 / 15
2	20	RVL/ 2C / 181 / 20